

INSTRUCTIONS:

1. Insert the bare terminal on the tan wire into the mating accessory connector as shown below, then plug that connector back into the dash harness accessory connection.
2. Plug the power top harness into the motor connection and into the power top switch.
3. Remove the 30A fuse from the "BAT 2" location in the fuse panel and replace it with the provided 30 A circuit breaker. This breaker will need to be trimmed as shown below, before inserting.



www.americanautowire.com 856-933-0801

This mating connector has been pre-plugged into the dash harness from the factory.

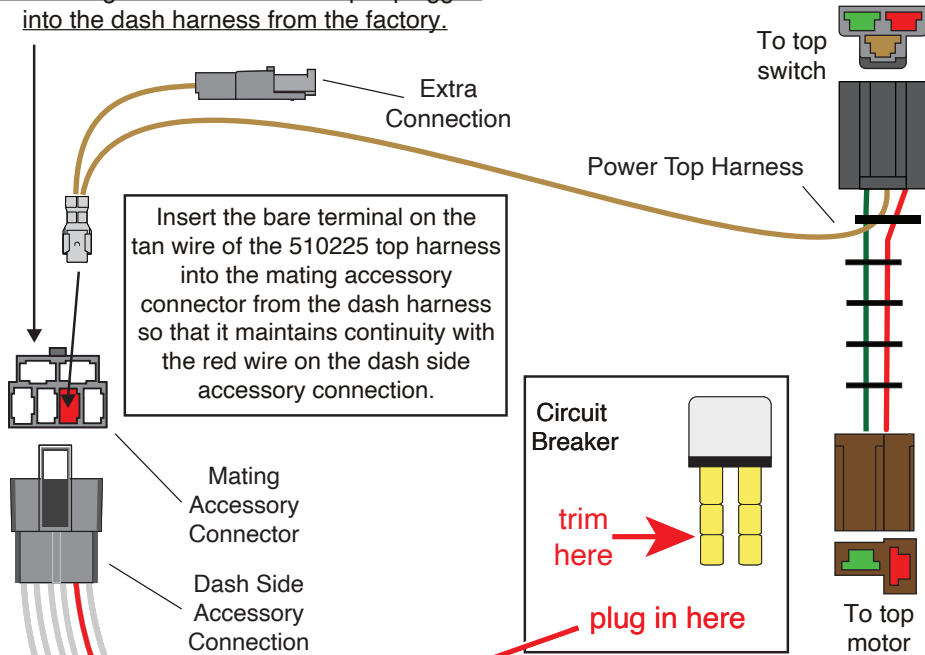

Insert the bare terminal on the tan wire of the 510225 top harness into the mating accessory connector from the dash harness so that it maintains continuity with the red wire on the dash side accessory connection.

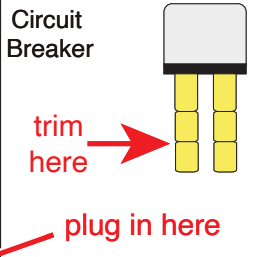

PART # **510225**
DESCRIPTION:
POWER TOP KIT
1959-1960 IMPALA
Classic Update Series
92969722 Instruction Sheet rev 1.0 5/29/2024

Dash Harness Fuse Panel

INSTRUCTIONS:

1. Insert the bare terminal on the tan wire into the mating accessory connector as shown below, then plug that connector back into the dash harness accessory connection.
2. Plug the power top harness into the motor connection and into the power top switch.
3. Remove the 30A fuse from the "BAT 2" location in the fuse panel and replace it with the provided 30 A circuit breaker. This breaker will need to be trimmed as shown below, before inserting.



www.americanautowire.com 856-933-0801

This mating connector has been pre-plugged into the dash harness from the factory.

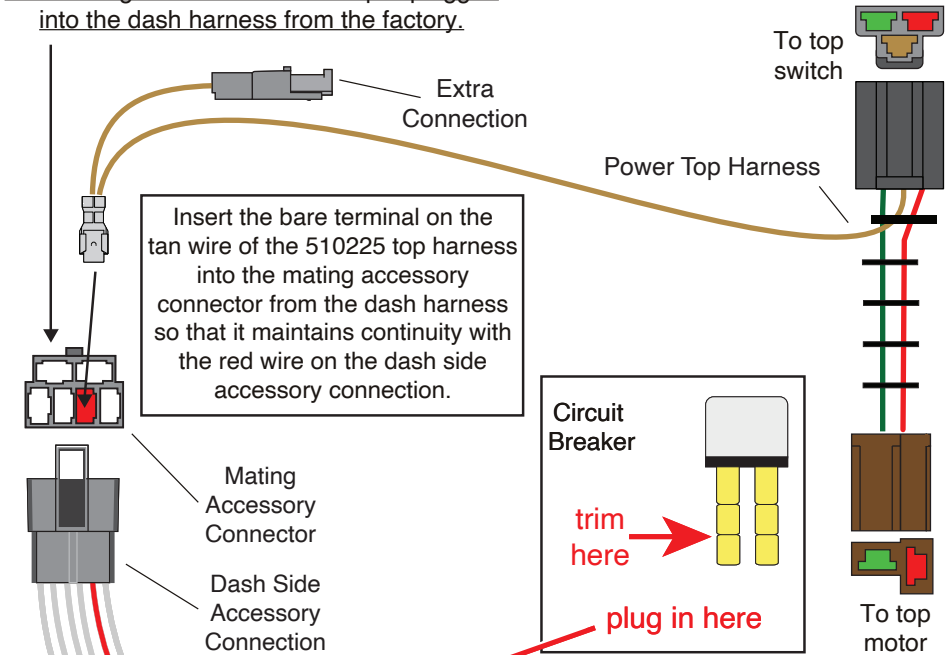

Insert the bare terminal on the tan wire of the 510225 top harness into the mating accessory connector from the dash harness so that it maintains continuity with the red wire on the dash side accessory connection.

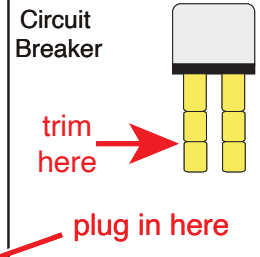

PART # **510225**
DESCRIPTION:
POWER TOP KIT
1959-1960 IMPALA
Classic Update Series
92969722 Instruction Sheet rev 1.0 5/29/2024

Dash Harness Fuse Panel